

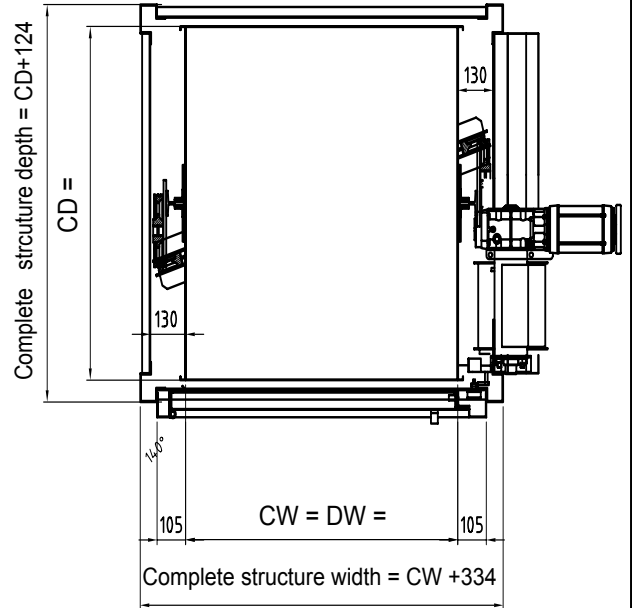

- Undercounter lift ISO-U

• Hinged doors serv. at floor level • Loading front and rear • Machine side below • **WITHOUT SAFETY GEAR**

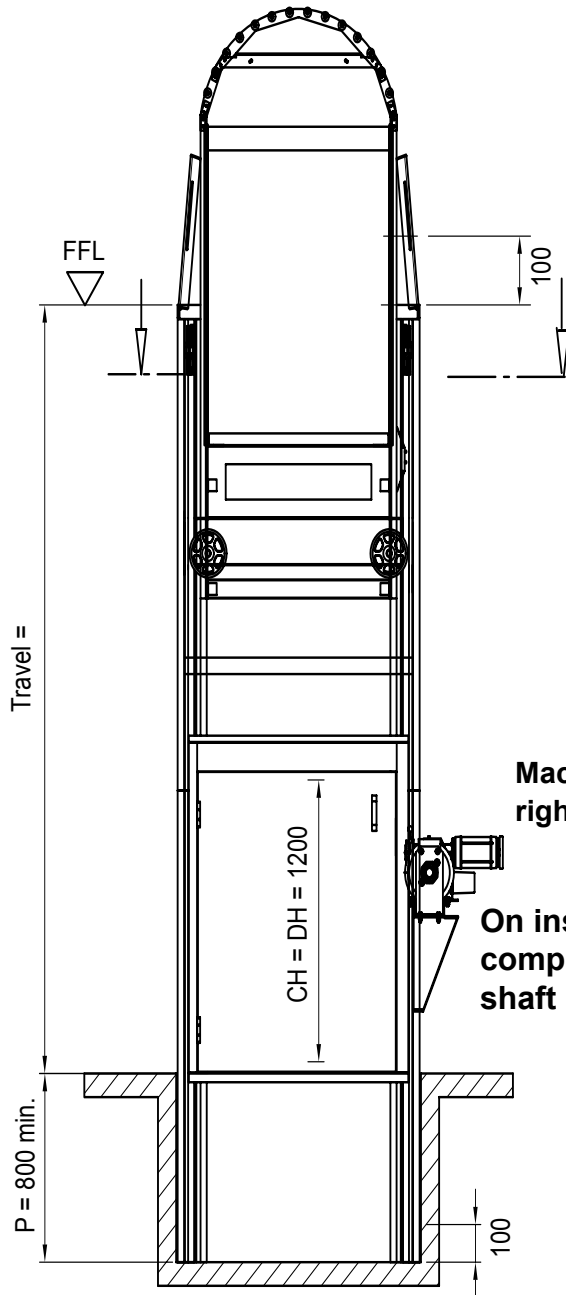

Machine can be positioned below left or right side!

On installation in an existing shaft, the min. width is: complete structure width + 40 mm and the min. shaft depth is: complete structure depth + 40 mm

ATTENTION:

Cabin protection reduces clear entrance openings resp. shaft sizes (see part 10)

Accessible rooms underneath shaft inadmissible

- CW = cabin width = 800 or 1000 mm
- CD = cabin depth = 800 or 1000 mm
- CH = cabin height = 1200 mm
- DW = door width = Cabin width
- DH = door height = Cabin height
- P = pit = min. 600 mm
- SW = Shaft width = plumbed min. dimensions
- SD = Shaft depth = plumbed min. dimensions
- FFL = finished floor level

