

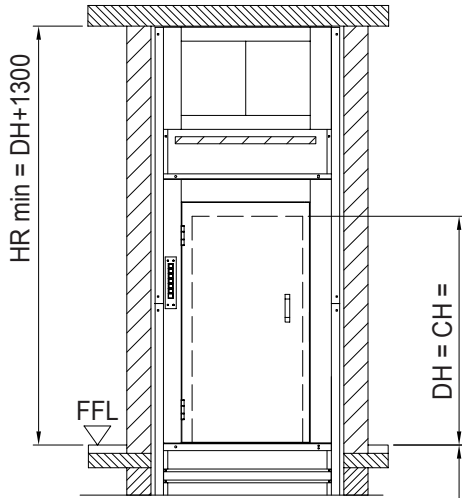

- Lift unit for pallets ISO - MAX 1000

• Hinged doors serv. at floor level • Loading front and rear • Machine above • WITH SAFETY GEAR

Well dimensions are absolute min. plumbed dimensions



All doors drawn left hinged
Doors right hinged mirror-image

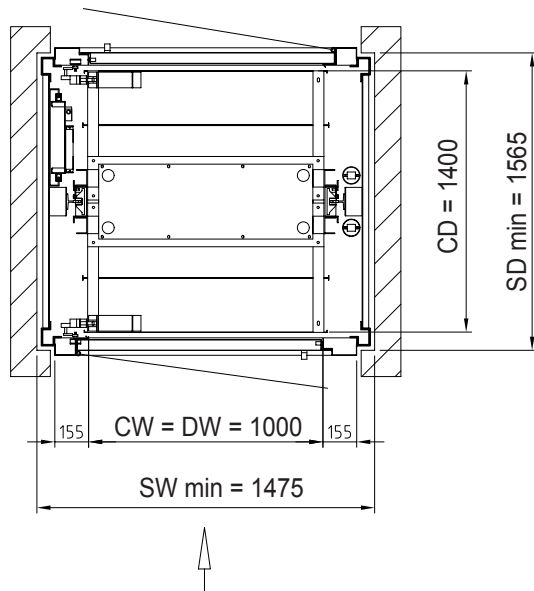

machine room access

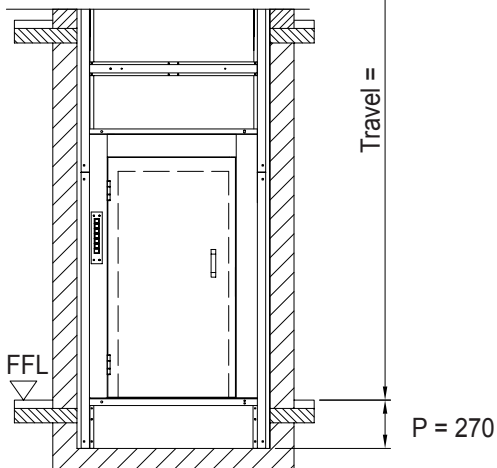

ATTENTION:

Cabin protection reduces clear entrance openings resp. shaft sizes (see part 10)

Shaft floor to be constructed according to layout drawing

Cabin height available in increments of 100 mm

- CW = cabin width **1000 mm**
- CD = cabin depth **1400 mm**
- CH = cabin height **min. 1200 - max. 2000 mm**
- DW = door width = Cabin width
- DH = door height = Cabin height
- P = pit = min. 270 mm
- SW = Shaft width = plumbed min. dimensions
- SD = Shaft depth = plumbed min. dimensions
- HR = Headroom = clear height of top floor FFL - underside ceiling
- FFL = finished floor level



Prices and specification see back side