

Well dimensions are absolute min. plumbed dimensions

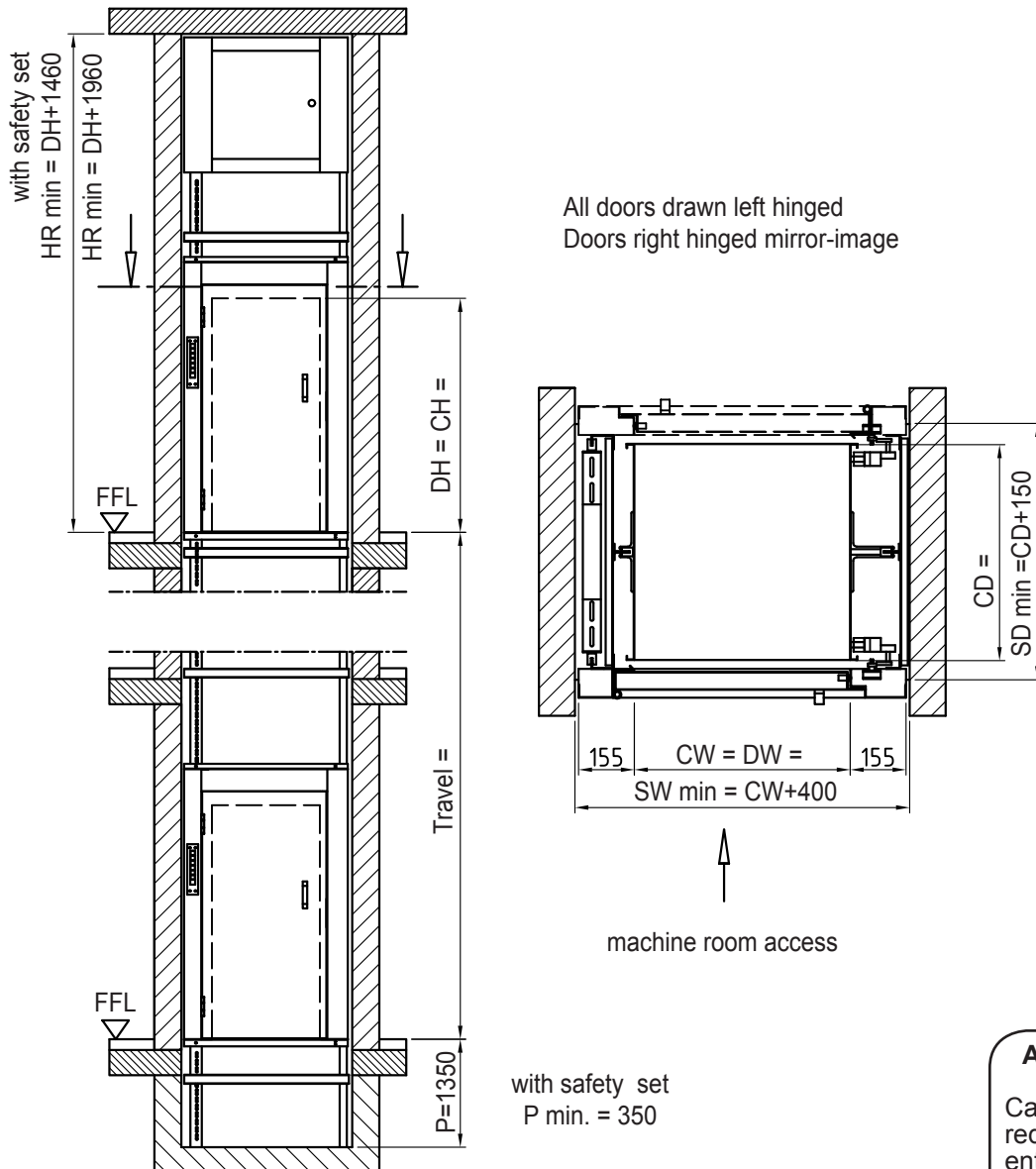

ATTENTION:

Cabin protection reduces clear entrance openings resp. shaft sizes (see part 10)

Shaft floor to be constructed according to layout drawing

Cabin width and -depth available in increments of 50 mm
 Cabin height available in increments of 100 mm

CW	=	cabin width	min. 800 - max. 1400 mm
CD	=	cabin depth	min. 800 - max. 1400 mm
CH	=	cabin height	2000 with safety set - min.1200 max. 2000 mm
DW	=	door width	= Cabin width
DH	=	door height	= Cabin height
P	=	pit	= min. 1350 mm with safety set - min.350 mm
SW	=	Shaft width	= plumbed min. dimensions
SD	=	Shaft depth	= plumbed min. dimensions
HR	=	Headroom	= clear height of top floor FFL - underside ceiling
FFL	=	finished floor level	



Prices and specification see back side