

Well dimensions are absolute min. plumbed dimensions

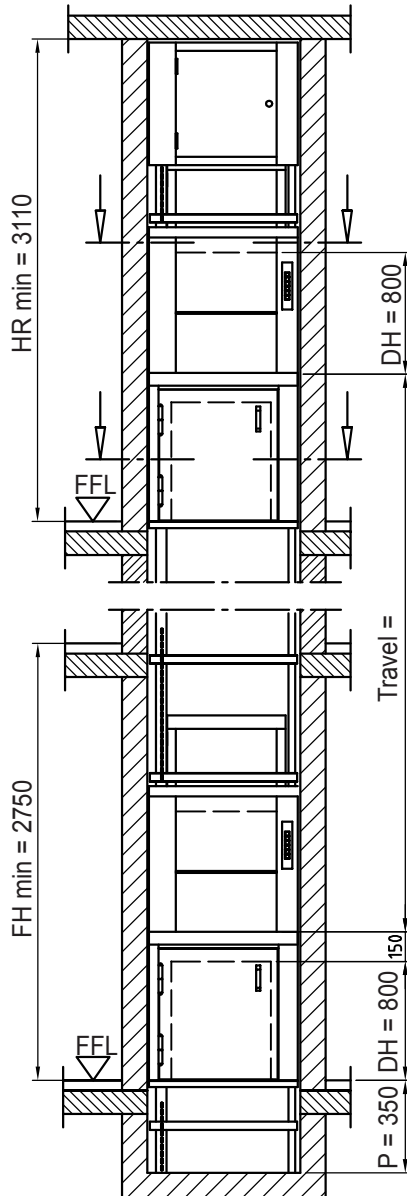

All doors drawn left hinged
Doors right hinged mirror-image

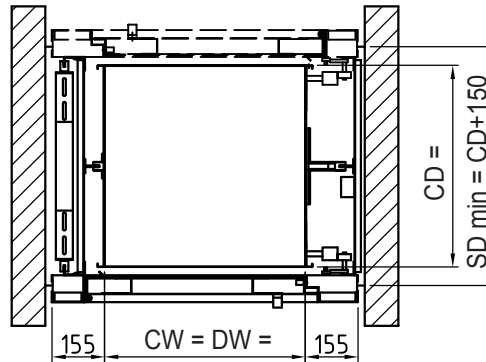
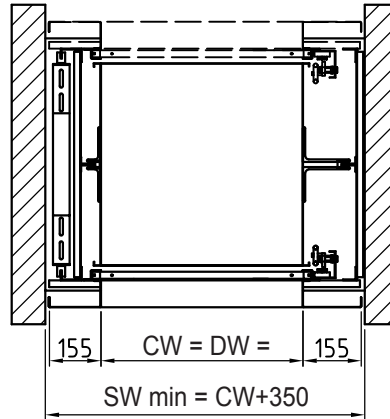

↑
machine room access

ATTENTION:

Cabin protection reduces clear entrance openings resp. shaft sizes (see part 10)

Accessible rooms underneath shaft inadmissible

Cabin width and -depth available in increments of 50 mm
Cabin height available in increments of 100 mm

- CW = cabin width **min. 500 - max. 1000 mm**
- CD = cabin depth **min. 600 - max. 1000 mm**
- CH = cabin height **1750 - 2000 mm (1750 standard dimension)**
- DH = door height = 800 mm each compartment
- P = pit = min. 350 mm
- SW = Shaft width = plumbed min. dimensions
- SD = Shaft depth = plumbed min. dimensions
- HR = Headroom = clear height of top floor FFL - underside ceiling
- FFL = finished floor level
- FH = Floor to floor height on landing doors in line

Prices and specification see back side

