

Well dimensions are absolute min. plumbed dimensions

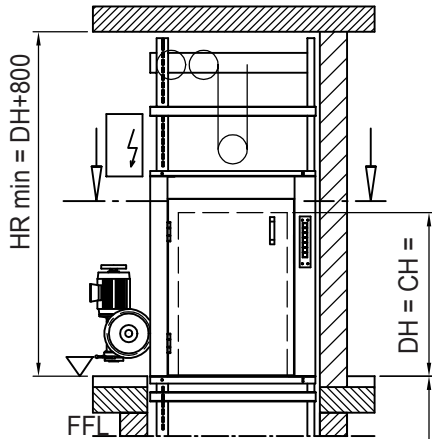

All doors drawn left hinged
Doors right hinged mirror-image

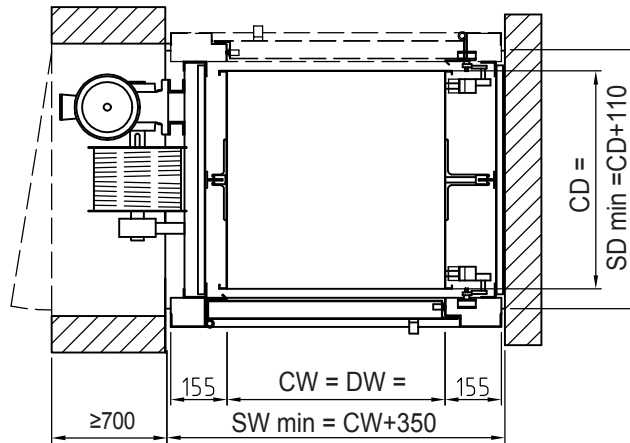
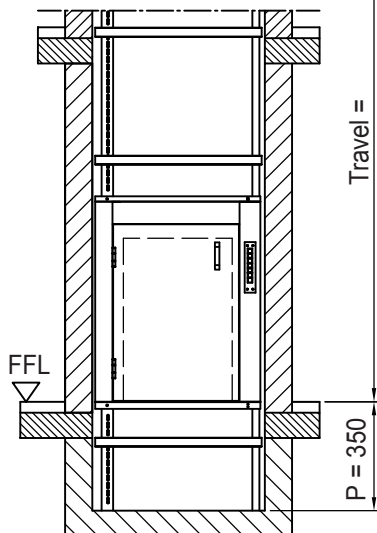

ATTENTION:
Machine room door by others
Position of machine room
(left or right) to be advised with reference
to the upper landing door !

ATTENTION:

Cabin protection
reduces clear
entrance openings
resp. shaft sizes
(see part 10)

Accessible rooms underneath shaft inadmissible

Cabin width and -depth available in increments of 50 mm
Cabin height available in increments of 100 mm

CW	=	cabin width	min. 500 - max. 1000 mm
CD	=	cabin depth	min. 650 - max. 1000 mm
CH	=	cabin height	min. 800 - max. 1200 mm
DW	=	door width	= Cabin width
DH	=	door height	= Cabin height
P	=	pit	= min. 350 mm
SW	=	Shaft width	= plumbed min. dimensions
SD	=	Shaft depth	= plumbed min. dimensions
HR	=	Headroom	= clear height of top floor FFL - underside ceiling
FFL	=	finished floor level	



Prices and specification see back side