

- Servicelift

ISO - D

• Hinged doors serv. at floor level • Loading front and rear • Machine above • **WITH SAFETY GEAR**

Well dimensions are absolute min. plumbed dimensions

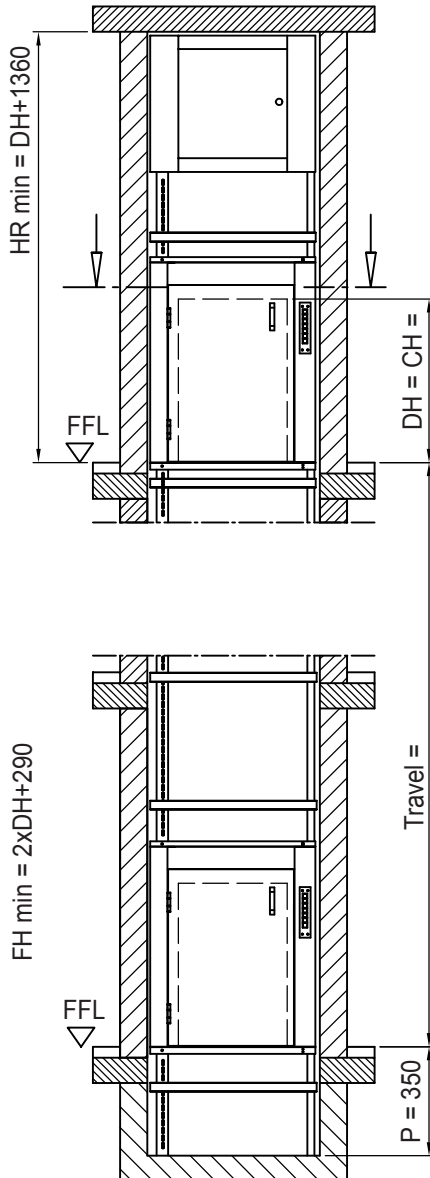

All doors drawn left hinged
Doors right hinged mirror-image

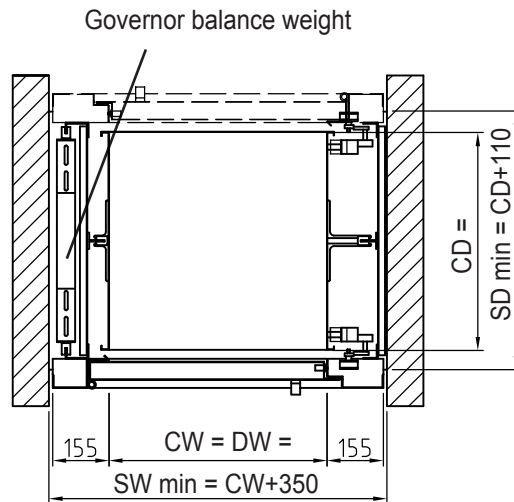

↑
machine room access

ATTENTION:

Cabin protection reduces clear entrance openings resp. shaft sizes (see part 10)

Shaft floor to be constructed according to layout drawing

Cabin width and -depth available in increments of 50 mm
Cabin height available in increments of 100 mm

- | | | | | |
|-----|---|----------------------|---|---|
| CW | = | cabin width | = | min. 600 - max. 1000 mm |
| CD | = | cabin depth | = | min. 700 - max. 1000 mm |
| CH | = | cabin height | = | min. 800 - max. 1200 mm |
| DW | = | door width | = | Cabin width |
| DH | = | door height | = | Cabin height |
| P | = | pit | = | min. 350 mm |
| SW | = | Shaft width | = | plumbed min. dimensions |
| SD | = | Shaft depth | = | plumbed min. dimensions |
| HR | = | Headroom | = | clear height of top floor FFL - underside ceiling |
| FFL | = | finished floor level | | |



Prices and specification see back side