

**Well dimensions are absolute min. plumbed dimensions**

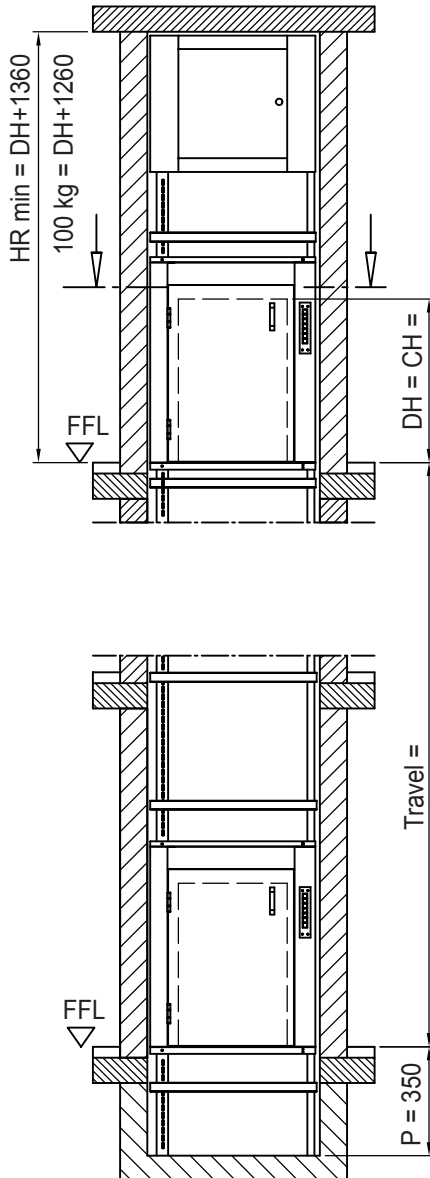

All doors drawn left hinged  
Doors right hinged mirror-image

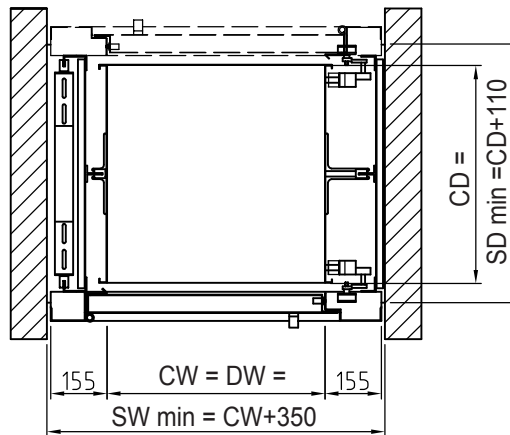

↑  
machine room access

**ATTENTION:**

Cabin protection reduces clear entrance openings resp. shaft sizes (see part 10)

**Accessible rooms underneath shaft inadmissible**

Cabin width and -depth available in increments of 50 mm  
Cabin height available in increments of 100 mm

- |     |   |                      |   |   |
|-----|---|----------------------|---|---|
| CW  | = | cabin width          |   | <b>min. 500 - max. 1000 mm</b>                    |
| CD  | = | cabin depth          |   | <b>min. 600 - max. 1000 mm</b>                    |
| CH  | = | cabin height         |   | <b>min. 800 - max. 1200 mm</b>                    |
| DW  | = | door width           | = | Cabin width                                       |
| DH  | = | door height          | = | Cabin height                                      |
| P   | = | pit                  | = | min. 350 mm                                       |
| SW  | = | Shaft width          | = | plumbed min. dimensions                           |
| SD  | = | Shaft depth          | = | plumbed min. dimensions                           |
| HR  | = | Headroom             | = | clear height of top floor FFL - underside ceiling |
| FFL | = | finished floor level |   |   |



**Prices and specification see back side**