

Well dimensions are absolute min. plumbed dimensions

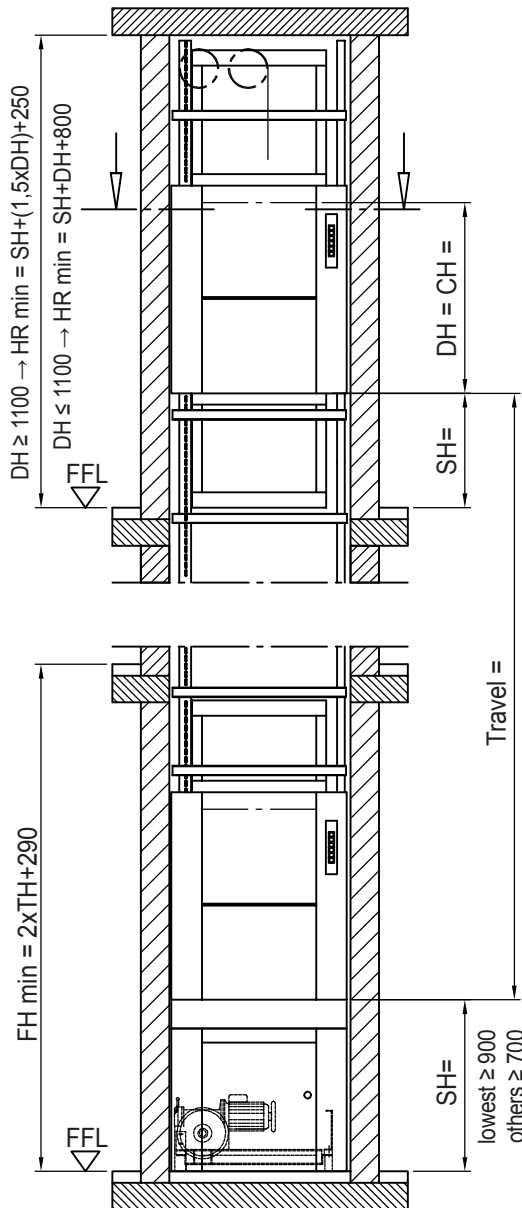

Attention:

Acceptance of machine room position

to be clarified with local authorities

Controller to be located in cabinet outside of shaft

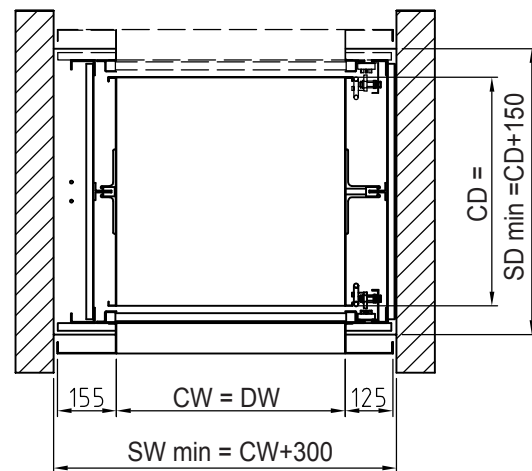

machine room access

ATTENTION:

Cabin protection reduces clear entrance openings resp. shaft sizes (see part 10)

Accessible rooms underneath shaft inadmissible

Cabin width and -depth available in increments of 50 mm

Cabin height available in increments of 100 mm

CW	= cabin width	min. 500 - max. 1000 mm
CD	= cabin depth	min. 650 - max. 1000 mm
CH	= cabin height	min. 600 - max. 1200 mm
DW	= door width	= Cabin width
DH	= door height	= Cabin height
SH	= Serving height	= lowest min. 900 mm, others min. 700 mm
SW	= Shaft width	= plumbed min. dimensions
SD	= Shaft depth	= plumbed min. dimensions
HR	= Headroom	= clear height of top floor FFL - underside ceiling
FFL	= finished floor level	
FH	= Floor to floor height on landing doors in line	



Prices and specification see back side