

**Well dimensions are absolute min. plumbed dimensions**

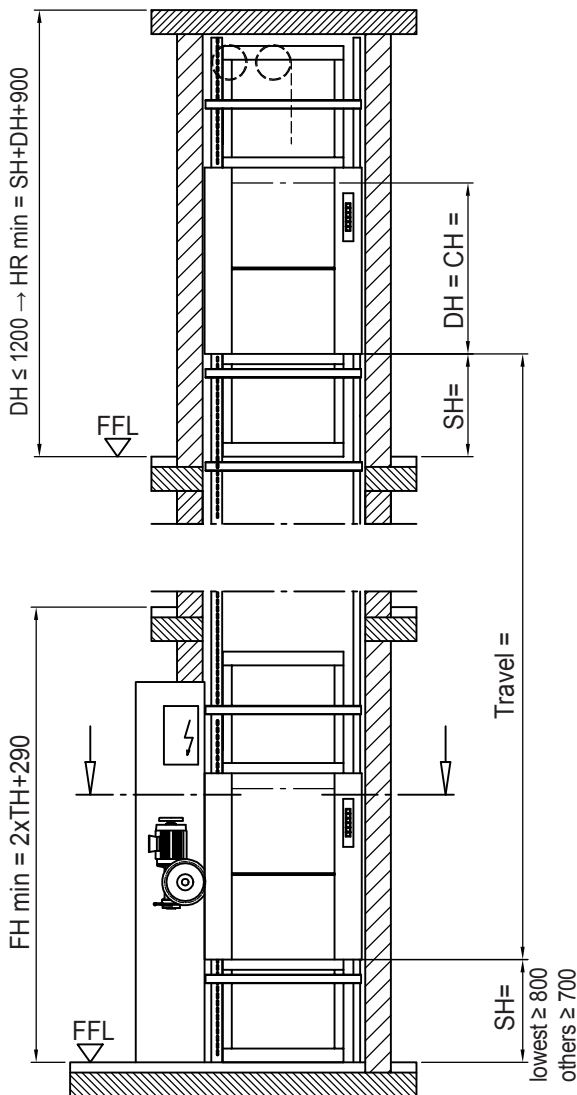

**ATTENTION:**  
Machine room door by others  
Position of machine room  
in relation (left or right) to be advised  
to the lower landing door !

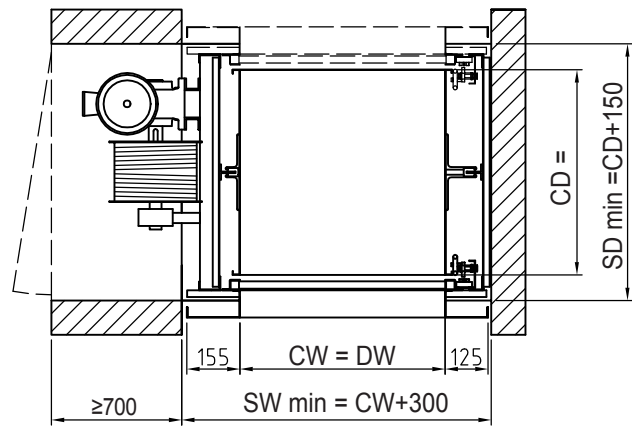

**ATTENTION:**

Cabin protection  
reduces clear  
entrance openings  
resp. shaft sizes  
(see part 10)

**Shaft floor to be constructed according to layout drawing**

Cabin width and -depth available in increments of 50 mm

Cabin height available in increments of 100 mm

CW	= cabin width	<b>min. 400 - max. 1000 mm</b>
CD	= cabin depth	<b>min. 700 - max. 1000 mm</b>
CH	= cabin height	<b>min. 600 - max. 1200 mm</b>
DW	= door width	= Cabin width
DH	= door height	= Cabin height
SH	= Serving height	= min. 700 mm resp. DH/2+50
SW	= Shaft width	= plumbed min. dimensions
SD	= Shaft depth	= plumbed min. dimensions
HR	= Headroom	= clear height of top floor FFL - underside ceiling
FFL	= finished floor level	
FH	= Floor to floor height on landing doors in line	



**Prices and specification see back side**