

Well dimensions are absolute min. plumbed dimensions

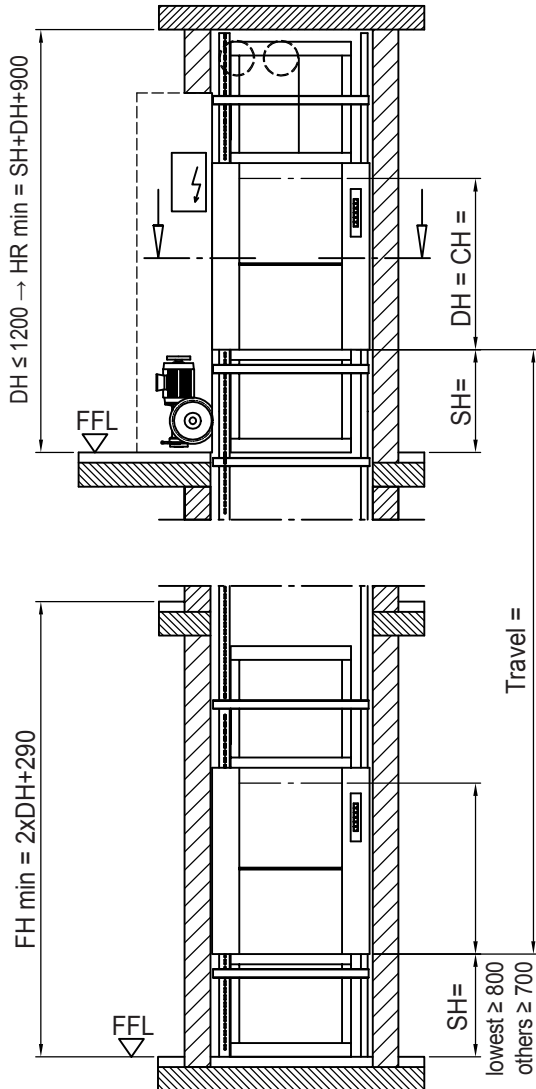

ATTENTION:

Machine room door by others
Position of machine room
in relation (left or right) to be advised
to the upper landing door !

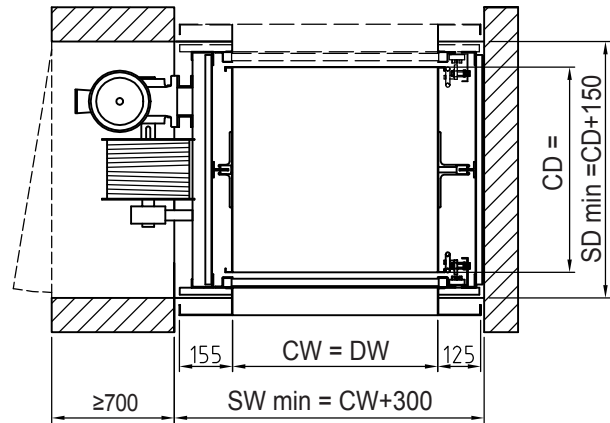

ATTENTION:

Cabin protection
reduces clear
entrance openings
resp. shaft sizes
(see part 10)

Shaft floor to be constructed according to layout drawing

Cabin width and -depth available in increments of 50 mm

Cabin height available in increments of 100 mm

CW	= cabin width	min. 500 - max. 1000 mm
CD	= cabin depth	min. 700 - max. 1000 mm
CH	= cabin height	min. 600 - max. 1200 mm
DW	= door width	= Cabin width
DH	= door height	= Cabin height
SH	= Serving height	= min. 700 mm resp. DH/2+50
SW	= Shaft width	= plumbed min. dimensions
SD	= Shaft depth	= plumbed min. dimensions
HR	= Headroom	= clear height of top floor FFL - underside ceiling
FFL	= finished floor level	
FH	= Floor to floor height on landing doors in line	



Prices and specification see back side