

Well dimensions are absolute min. plumbed dimensions

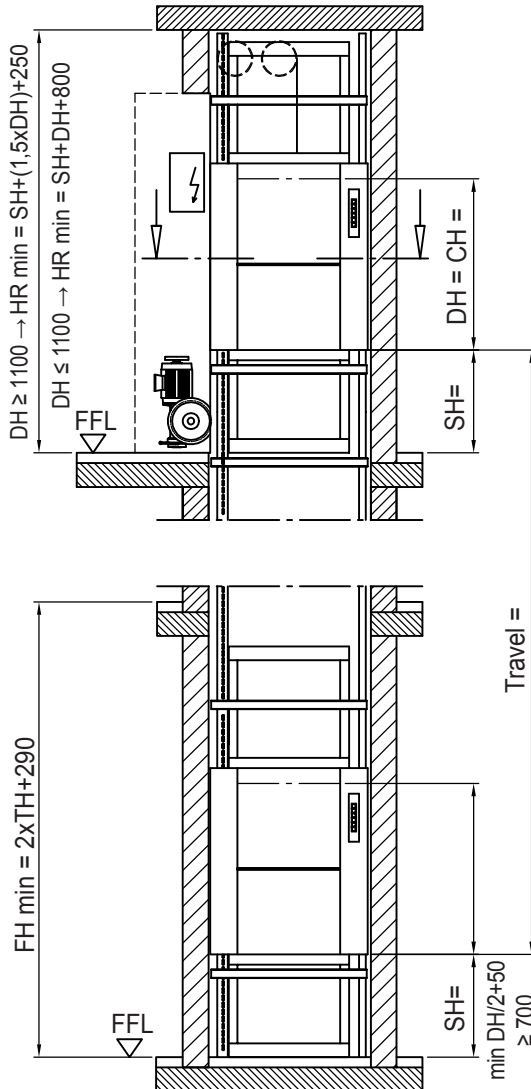

ATTENTION:
Machine room door by others
Position of machine room
in relation (left or right) to be advised
to the upper landing door !

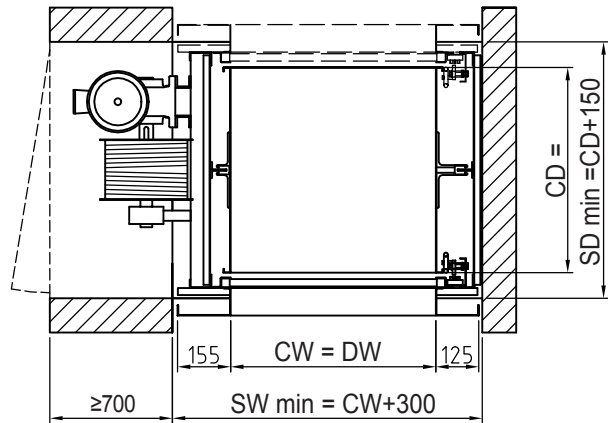

ATTENTION:

Cabin protection
reduces clear
entrance openings
resp. shaft sizes
(see part 10)

Accessible rooms underneath shaft inadmissible

Cabin width and -depth available in increments of 50 mm
Cabin height available in increments of 100 mm

- | | | | |
|-----|---|--|---|
| CW | = | cabin width | min. 500 - max. 1000 mm |
| CD | = | cabin depth | min. 650 - max. 1000 mm |
| CH | = | cabin height | min. 600 - max. 1200 mm |
| DW | = | door width | = Cabin width |
| DH | = | door height | = Cabin height |
| SH | = | Serving height | = min. 700 mm resp. DH/2+50 |
| SW | = | Shaft width | = plumbed min. dimensions |
| SD | = | Shaft depth | = plumbed min. dimensions |
| HR | = | Headroom | = clear height of top floor FFL - underside ceiling |
| FFL | = | finished floor level | |
| FH | = | Floor to floor height on landing doors in line | |



Prices and specification see back side